

Motorcycle

Harley Davidson

Flange Part #	Application	Lightened / Face Relieved	Flange ID	Material Thickness	Material
F5302104			1.880"	.375"	1018
F5302304			1.880"	.375"	304 SST

Weld-on (not compression style)



Ducati

Flange Part #	Application	Lightened / Face Relieved	Tube Size	Material Thickness	Material
F5344105	999		2.00"	.375" / .250"	1018
F5344305			2.00"	.375" / .250"	304 SST



	1098	✓		.500" / .250"	1018
		✓		.500" / .250"	304 SST

(Counterbored & Face relieved)



Triumph

Flange Part #	Application	Lightened / Face Relieved	Flange ID	Material Thickness	Material
F5552601		✓	1.530"	.375" / .250"	1018
F5552801		✓	1.530"	.375" / .250"	304 SST
F5552602		✓	1.650"	.375" / .250"	1018
F5552802		✓	1.650"	.375" / .250"	304 SST
F5552603		✓	1.760"	.375" / .250"	1018
F5552803		✓	1.760"	.375" / .250"	304 SST



Japanese

Flange Part #	Application	Lightened / Face Relieved	Flange ID	Bolt Center	Material Thickness	Material
F5492101	Yamaha R1 & R6 except R6V		1.530"	58mm	.375"	1018
F5492301			1.530"	58mm	.375"	304 SST
F5492601		✓	1.530"	58mm	.375" / .250"	1018
F5492801	Suzuki 600-1000cc	✓	1.530"	58mm	.375" / .250"	304 SST
F5502101	Yamaha R6V		1.530"	60mm	.375"	1018
F5502301			1.530"	60mm	.375"	304 SST
F5502601		✓	1.530"	60mm	.375" / .250"	1018
F5502801		✓	1.530"	60mm	.375" / .250"	304 SST
F5512101	Kawasaki KZ1000		1.530"	62mm	.375"	1018
F5512301			1.530"	62mm	.375"	304 SST
F5512601		✓	1.530"	62mm	.375" / .250"	1018
F5512801	Honda	✓	1.530"	62mm	.375" / .250"	304 SST
F5512102			1.650"	62mm	.375"	1018
F5512302			1.650"	62mm	.375"	304 SST





V-Band

Available in 1020 carbon steel, 304 stainless

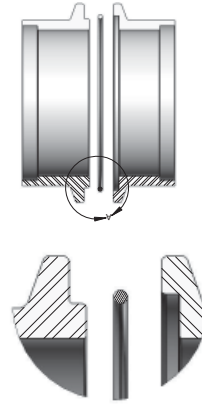
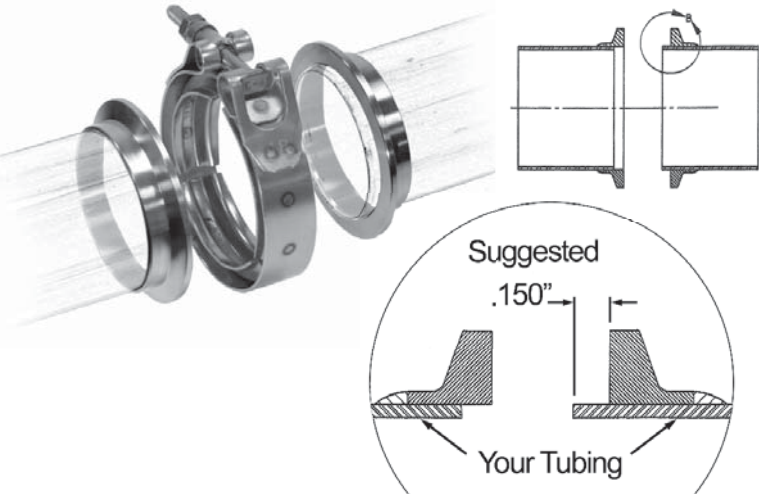
& 6160 aluminum



Tube Size OD	V-Band Kit	V-Band Clamp	Steel Sealing Flange	Aluminum Sealing Flange	O-Ring Size	V-Band Assembly
NEW! 1.75"	VBK150	VBC150	SF150			VBA150
1.75"	VBK175	VBC175	SF175			VBA175
2.00"	VBK200	VBC200	SF200			VBA200
2.25"	VBK225	VBC225	SF225			VBA225
2.50"	VBK250	VBC250	SF250	SF250A (M or F)		VBA250
NEW! 2.75"	VBK275	VBC275	SF275			VBA275
3.00"	VBK300	VBC300	SF300	SF300A (M or F)		VBA300
3.50"	VBK350	VBC350	SF350	SF350A (M or F)		VBA350
4.00"	VBK400	VBC400	SF400	SF400A (M or F)		VBA400
4.50"	VBK450	VBC450	SF450			VBA450
5.00"	VBK500	VBC500	SF500			VBA500
						
Includes	(1) Clamp (2) Sealing Flanges	(1) Clamp	(1) Sealing Flange	(1) Sealing Flange <i>Specify: Male or Female</i>		(1) Clamp (2) Sealing Flanges (2) 3" Stub Tubes (2) Weld Fees

Add a "S" for 304 Stainless Steel example: (VBK300S or SF300S)

Add a "A" for 6061 Aluminum example: (VBK300A or SF300MA)

Replacement Hardware	Clampco	R.G. Ray
T-Bolt (1/4-28)	600410-300	C1037-20
Lock Nut	C1315	

All clamps are made of Stainless Steel

CNC Exhaust Flanges

2 Bolt

Flange Part #	Use Gasket P/N	Flange ID	"A" Bolt Center	Material Thickness
F150-2CNC	EG150-2	1.500	2.63	0.375
F163-2CNC	EG163-2	1.625	2.63	0.375
F175-2CNC	EG175-2	1.750	3.00	0.375
F188-2CNC	EG188-2	1.875	3.00	0.375
F200-2CNC	EG200-2	2.000	3.00	0.375
F213-2CNC		2.125	3.00	0.375
F225-2CNC	EG225-2	2.250	3.50	0.375
F250-2CNC	EG250-2	2.500	3.88	0.375
F300-2CNC		3.000	4.12	0.375

SPD 2 bolt flanges are designed to fit the standard flange patterns used in the exhaust industry.

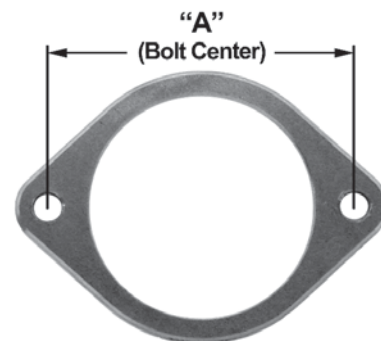

Add a "S" for 304 stainless steel
Example: (F300-2SCNC)

▼ Special Flanges ▼

F175-2CNC2		1.750	2.750	0.375
F188-2CNC2		1.875	2.750	0.375
F163-2CNC1	Flathead	1.625	2.875	0.375
F175-2CNC1	Flathead	1.750	2.875	0.375

▼ See Also Specialty Exhaust Flanges ▼

Pages 62 & 63

3 Bolt

Flange Part #	Use Gasket P/N	Flange ID	"A"	"B"	Material Thickness
F200-3CNC	EG200-3	2.000	2.71	3.13	0.375
F225-3CNC	EG225-3	2.250	2.71	3.13	0.375
F250-3CNC	EG250-3	2.500	3.03	3.50	0.375
F275-3CNC		2.750	3.41	3.94	0.375
F300-3CNC	EG300-3	3.000	3.41	3.94	0.375
F350-3CNC	EG350-3	3.500	3.86	4.46	0.375

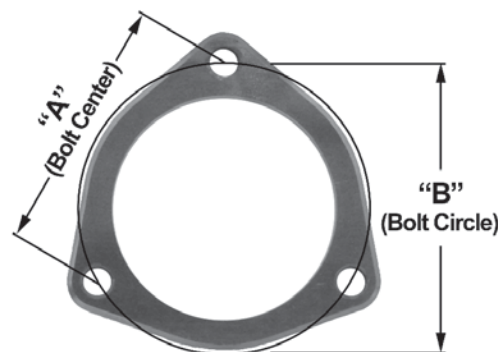

Add a "S" for 304 stainless steel
example: (F300-3SCNC)

▼ Porsche Exhaust Flange ▼

F225-3CNC-P		2.250	72mm	83mm	0.375
-------------	--	-------	------	------	-------

▼ See Also Specialty Exhaust Flanges ▼

Pages 62 & 63

Block Off Plate

Flange Part #	Use Gasket P/N	"A"	"B"	Material Thickness
F200-3BPCNC	EG200-3	2.71	3.13	0.375
F250-3BPCNC	EG250-3	3.03	3.50	0.375
F300-3BPCNC	EG300-3	3.41	3.94	0.375
F350-3BPCNC	EG350-3	3.86	4.46	0.375

Add a "S" for 304 stainless steel example: (F300-3SBPCNC)

SPD Block Off Plates allow one to cap the exhaust manifold / header outlets and run exhaust back under the car.

Used mostly on vintage Hot Rod "cut out" or "log" style manifolds.

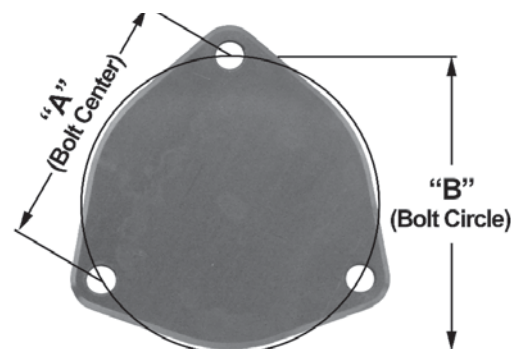

Specialty Flanges

BMW

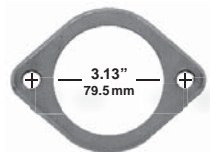

3.0CSI Outlet Flange

F5222808 .500 304 SST

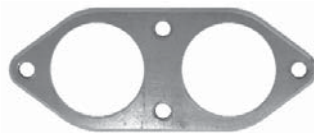

M30 Exhaust Flange

F5202507 .500 Mild Steel
F5202707 .500 304 SST

Mitsubishi Eclipse

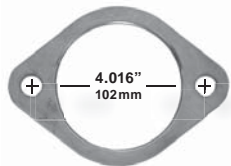

Catalytic Conv. Flange

F5122113 .375 304 SST



Muffler Flange

F5112113 .375 304 SST

Porsche

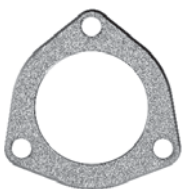

Exhaust Flange

2.125" F5602106 .375 Mild Steel
F5602306 .375 304SST

2.250" F5602107 .375 Mild Steel
F5602307 .375 304SST



996-997 Turbo Flange

1.875" F5612604 .500 Mild Steel
F5612804 .500 304SST

2.00" F5612605 .500 Mild Steel
F5612805 .500 304SST

Late Model GM

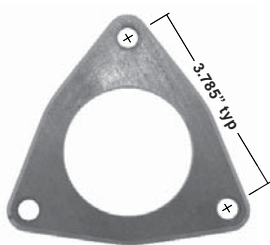

**Gen III Truck (Pass. Side)
2.50" I.D.**

F5172109 .375 Mild Steel
F5172609 .500 Mild Steel
F5172309 .375 304 SST
F5172809 .500 304 SST

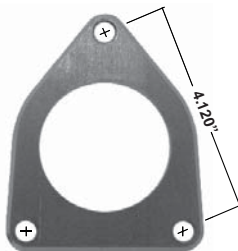

**Gen III Truck (Dr. Side)
2.50" I.D.**

F5162109 .375 Mild Steel
F5162609 .500 Mild Steel
F5162309 .375 304 SST
F5162809 .500 304

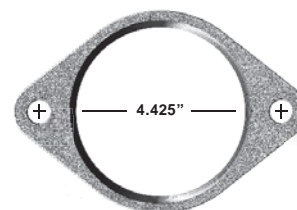

**2005 - up C6 Z06
Head pipe to Exhaust**

F5142614 .500 Mild Steel
F5142814 .500 304 SST



97-04 Corvette
(LS1 / LS2 / LS6 excludes LS7)

2.50" I.D.

F5152109 .375 Mild Steel
F5152309 .375 304 SST

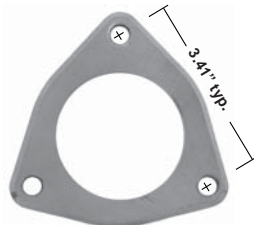

**95-02 Camaro (96-02 Pass. Side)
94-96 Caprice**

2.50" I.D.

F5262109 .375 Mild Steel
F5262309 .375 304 SST



**96-02 Camaro (Driver Side)
LT1 & LS1 2.63" I.D.**

F5252110 .375 Mild Steel
F5252310 .375 304 SST

Specialty Flanges

Maserati

1957-1964 3500 GT

MAS629226 2.125"
.500 304 Stainless

Bolt Circle 81 mm
Bolt to Bolt 70 mm

Ferrari

Lampredi V12 powered
Super America

FE1229725 2.00"
.375 Mild Steel

Bolt Circle 69.5 mm
Bolt to Bolt 60 mm



Ford GT

Catalytic Converter Flange
3.00" I.D.

F5062113 .375 Mild Steel
F5062613 .500 Mild Steel
F5062313 .375 304 SST
F5062813 .500 304 SST

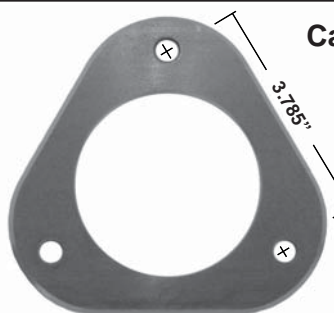

Manifold Flange

2.75" F5052611 .500 Mild Steel
3.00" F5052613 .500 Mild Steel
2.75" F5052811 .500 304 SST
3.00" F5052813 .500 304 SST

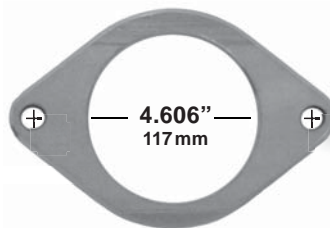

See page 42 for header flanges
F81155x

Flange Part #	Flange ID	Bolt Holes	Bolt Centers (bc)	Material Thickness
F5016114	1.875	8	2.250"	0.375
F5016115	2.000	8	2.250"	0.375
F5016116	2.125	8	2.250"	0.375
304 Stainless Steel				
F5016314	1.875	8	2.250"	0.375
F5016315	2.000	8	2.250"	0.375
F5016316	2.125	8	2.250"	0.375

Typically used on Cobras to join side pipes to the header tubes just inside the fender well.

Side Pipes

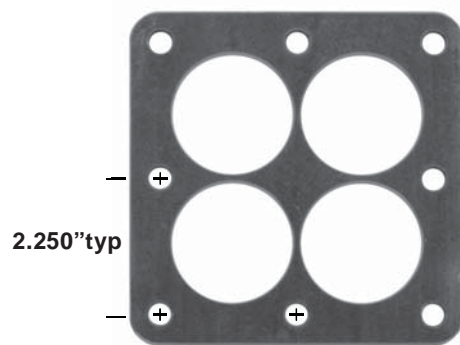

Collector Flange

Street & Performance
Shorty Header Collector Flange

F5405120 .375 Mild Steel
F5405320 .375 304 SST

